

**Montage-/
Demontageanleitung
für Gegenkasten
systemeQ-S-ESC 7663**

**Installation-/
disassembling
instruction for keep
systemeQ-S-ESC 7663**

**Hier: Montage
Here: Installation**

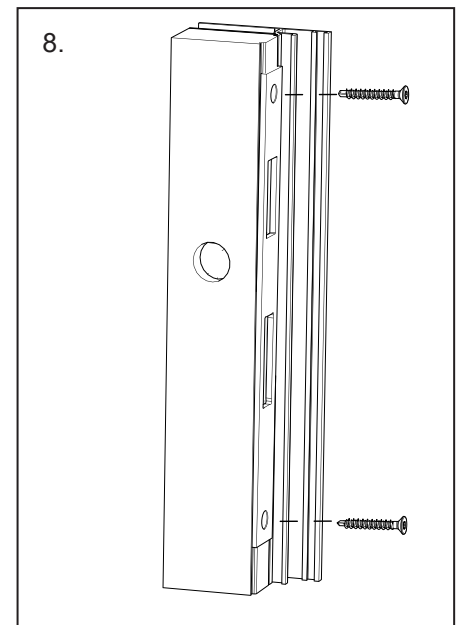
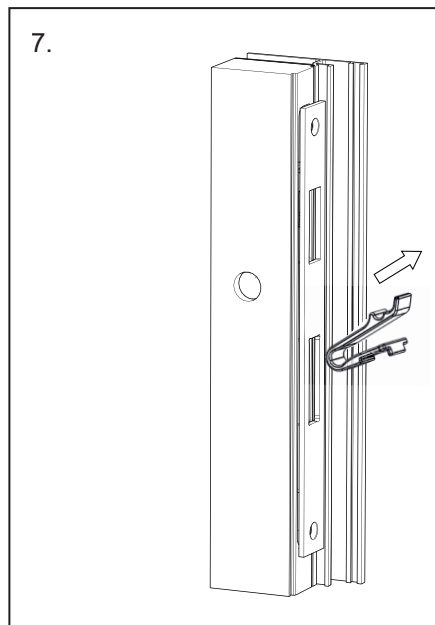
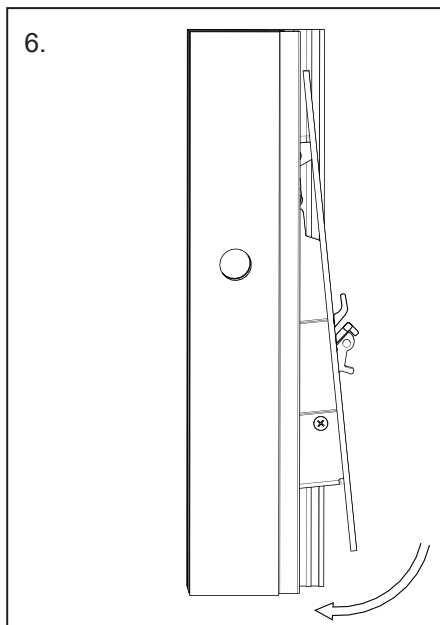
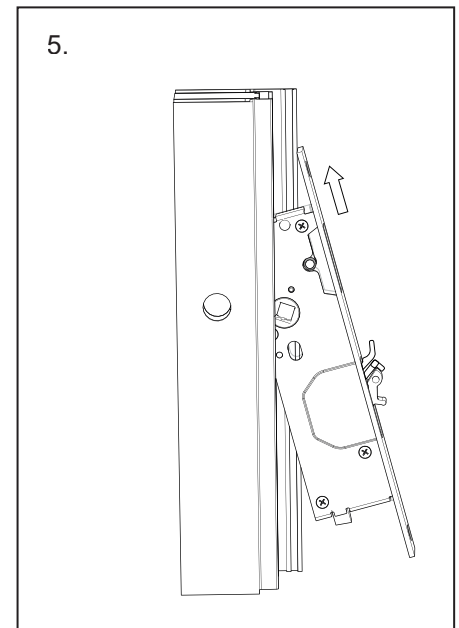
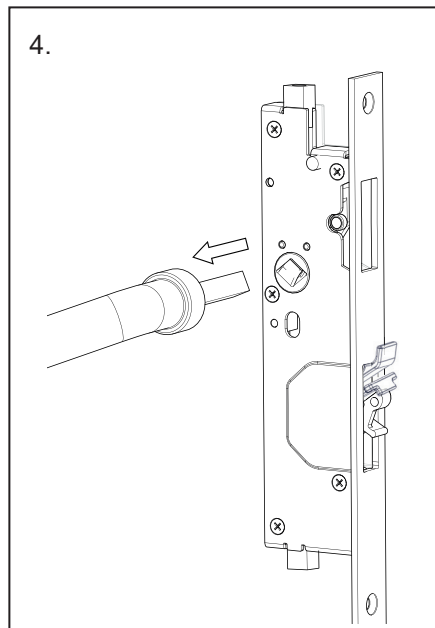
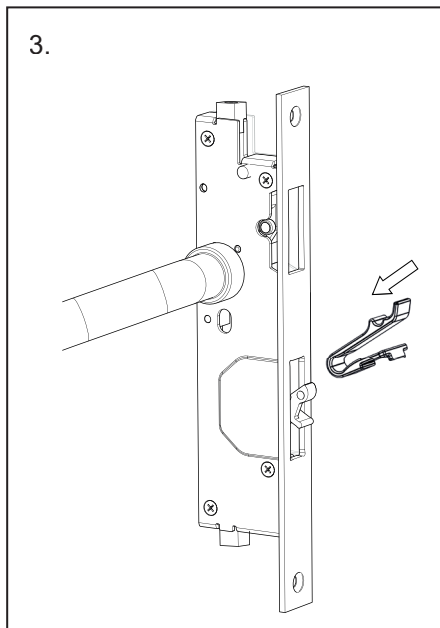
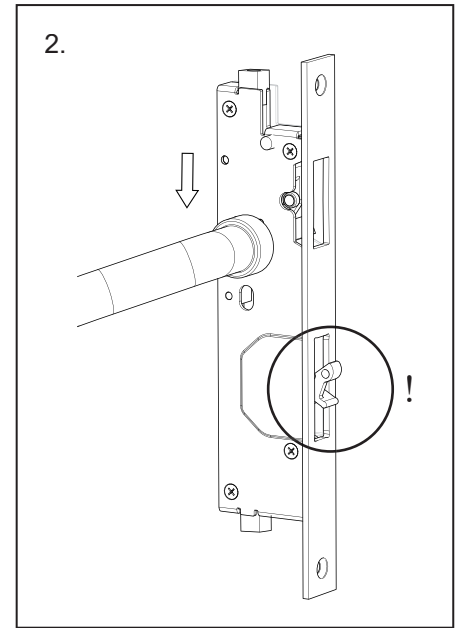
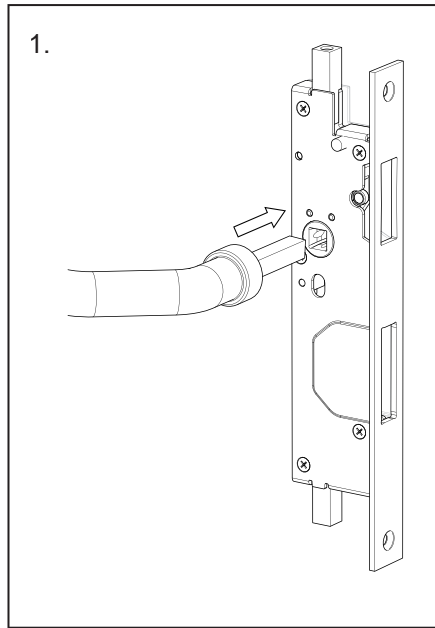

**Montage-/
Demontageanleitung
für Gegenkasten
systemeQ-S-ESC 7663**

**Installation-/
disassembling
instruction for keep
systemeQ-S-ESC 7663**

**Hier: Demontage
Here: Disassembling**

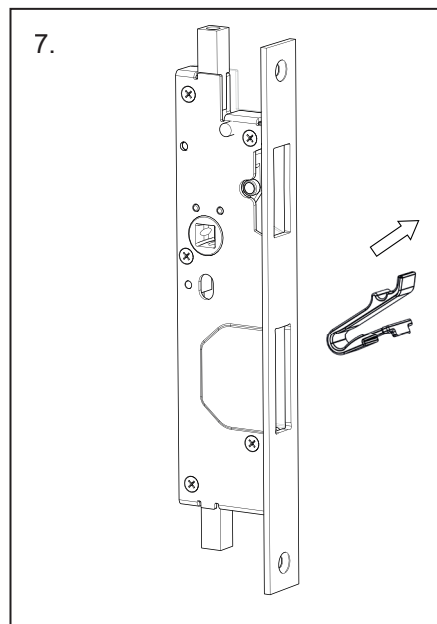
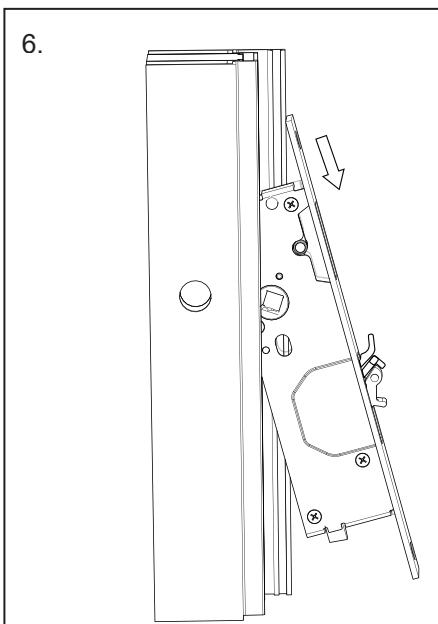
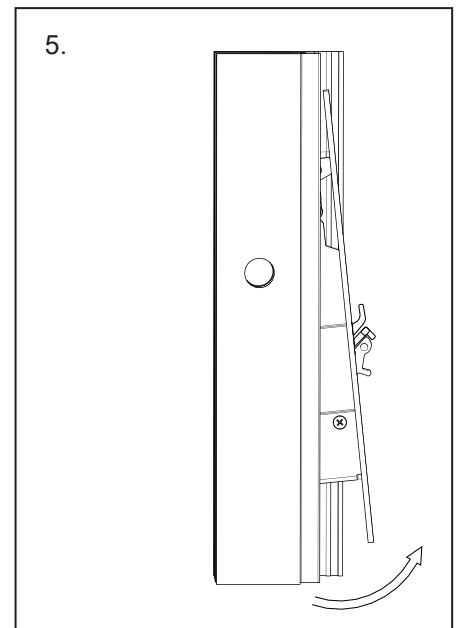
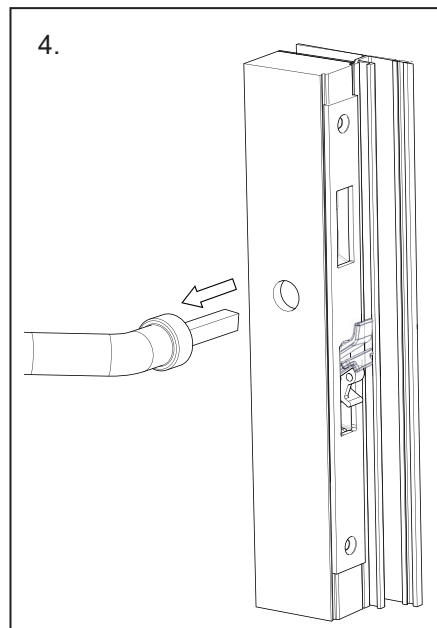
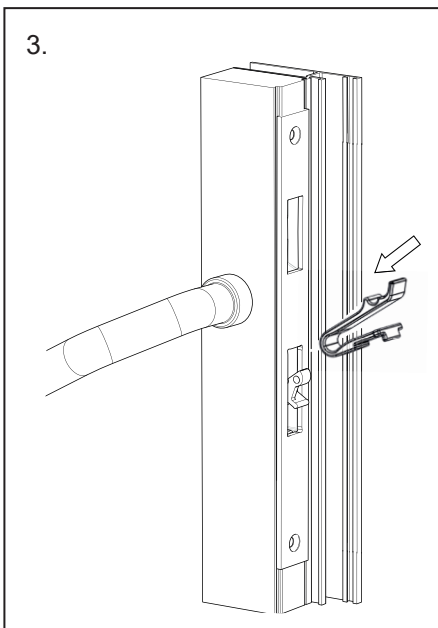
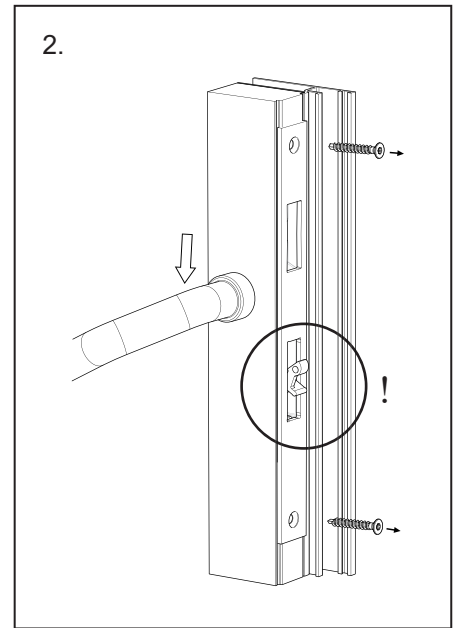
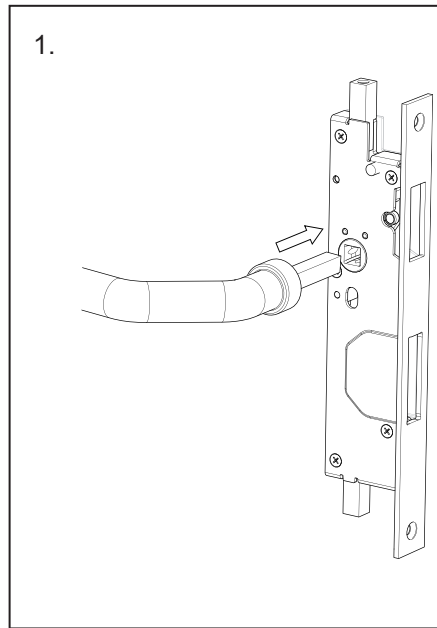



Montageanleitung für Gegenkästen mit Riegelüberwachung Installation instructions for keeps with dead bolt monitoring device Instructions de la montage pour gâches avec supervision du pêne dormant Introduzione die montaggio per controserratura con conduzione chiavistello

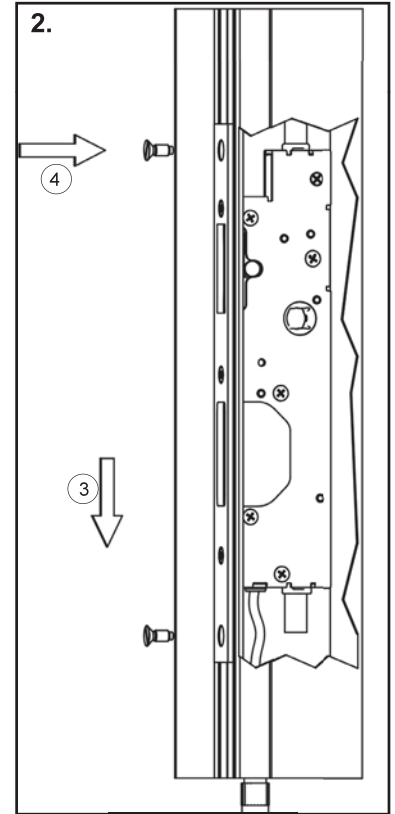
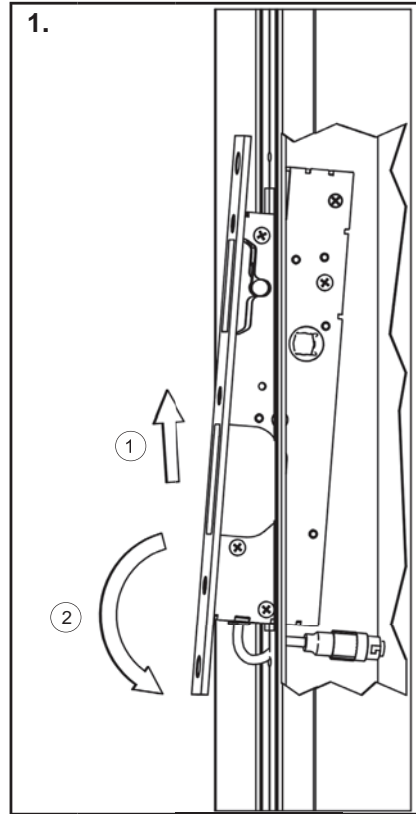
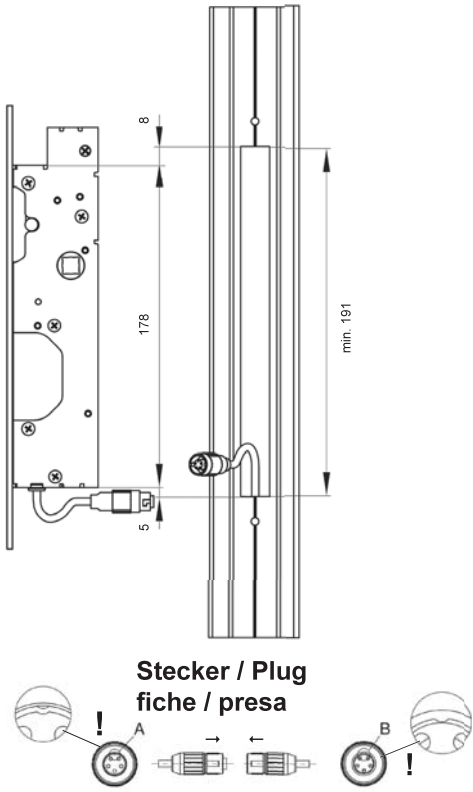

- Verwendung als Verschlussüberwachung VdS Sicherheitsklasse C
- Umweltklasse III nach VdS 2269
- VdS Anerkennungsnummer G116086
- Zugelassener Temperaturbereich -25° bis +70°C
- Zulassung nur gültig mit originale Systemstecker

- Utilisation pour la surveillance du verrouillage certification VdS classe de sécurité C
- Classe environnementale III selon VdS 2269
- N° d'agrément VdS G116086
- Plage de température autorisée de -25° à +70°C
- Homologation valable uniquement avec connecteur système d'origine

- Use as lock monitoring VdS safety class C
- Environmental class III according to VdS 2269
- VdS approval number G116086
- Approved temperature range -25 ° to +70 °C
- Approval only valid with original system connector

- Impiego come controllo chiusura VdS classe di sicurezza C
- Classe ambientale III secondo VdS 2269
- Codice riconoscimento VdS G116086
- Temperatura di esercizio ammessa da -25 ° C a +70 °C
- Omologazione valida solo con connettore di sistema originale

Leistungserklärungen im Rahmen der neuen Bauproduktenverordnung sowie weitere Informationen unter:

Further information and performance descriptions concerning the construction products see:

Informations et description d'alimentation voir:
Informazione e descrizione della prestazione:

www.esco-online.de

Leistungserklärung und Zertifikate
performance description and certificates

Riegelschaltkontakt / Dead bolt switch contact /
Contacte de pêne commutateur /
Contatto della serratura

grün/green/vert/verde



weiß/
white/
blanc/
blanco

C

no

nc

braun / brown /
brun / marrone

gelb / yellow /
jaune / giallo

grau / grey /
gris / grigio

Kontaktbelastung / Contact load / Taille d'un contact
Carico sul contatto: **max. 30V, 1A**